

Student Name: _____

Spring 2013
North Carolina
Measures of Student Learning:
NC's Common Exams
Physics



Student Booklet



Public Schools of North Carolina
State Board of Education
Department of Public Instruction
Raleigh, North Carolina 27699-6314

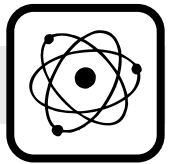

- 1 The graph below represents the displacement of an object over time.

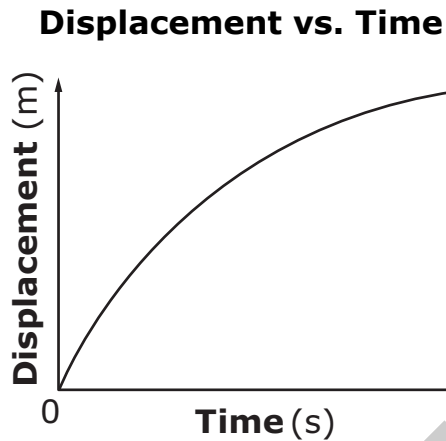

Which **best** describes the velocity of the object?

- A The velocity increases at a constant rate.
 - B The velocity remains the same.
 - C The velocity decreases at a constant rate.
 - D The velocity remains at zero.
- 2 What can be concluded about the shape of an acceleration vs. time graph when the instantaneous acceleration of an object and its average acceleration are the same?
- A It is a curved line.
 - B It is a zigzag line.
 - C It is a straight line parallel to the time axis.
 - D It is a straight line parallel to the acceleration axis.

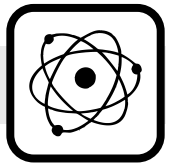

- 3 A car traveling at 6.1 m/s increases its speed to 36.5 m/s in 9.9 s. What assumption can be made about the acceleration of the car?
- A The instantaneous acceleration of the car is 2.2 m/s/s.
 - B The average acceleration of the car is 3.1 m/s/s.
 - C The instantaneous acceleration of the car is 3.7 m/s/s.
 - D The average acceleration of the car is 4.3 m/s/s.
- 4 A stone is dropped into water from a bridge 52 m above the water's surface. What can be determined about the stone when it reaches the water?
- A Its mass is 16 kg.
 - B Its velocity is -45 m/s.
 - C Its speed is 32 m/s.
 - D Its acceleration is -23 m/s/s.

RELEASED

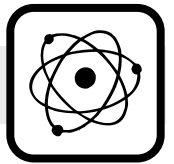

- 5 This table shows the relationship between the force on an object and the object's resulting acceleration.

Force vs. Acceleration

Force (N)	Acceleration (m/s/s)
0	0
4	2
8	4
12	6

What is the mass of the object?

- A 0.2 kg
- B 0.5 kg
- C 1 kg
- D 2 kg

RELEASED

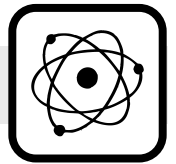

- 6 Two different forces act on an object moving on a frictionless surface.

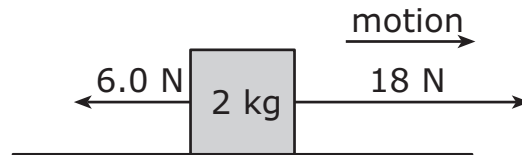

What amount of force is moving the object?

- A 6.0 N
- B 12 N
- C 18 N
- D 24 N
- 7 A car travels around a curved track. It moves twice as fast the second time around the track, as compared to the first time. What can be concluded about the centripetal force as the car travels around the track for the second time?
- A The centripetal force is one-fourth the original amount.
- B The centripetal force is one-half the original amount.
- C The centripetal force is twice the original amount.
- D The centripetal force is four times the original amount.
- 8 An object moves in uniform circular motion. What is true regarding the force on the object?
- A The direction is away from the center, and its magnitude varies.
- B The direction is toward the center, and its magnitude varies.
- C The direction is away from the center, and its magnitude is constant.
- D The direction is toward the center, and its magnitude is constant.

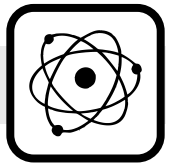

- 9 Two objects are held close to each other with a compressed spring between them. When the objects are released, one object moves at a speed of 0.63 m/s, and the other object moves at a speed of 0.45 m/s. If the faster object has a mass of 0.035 kg, what is the mass of the slower object?
- A less than 0.035 kg but greater than 0.0 kg
 - B equal to 0.035 kg
 - C greater than 0.035 kg but less than 0.070 kg
 - D greater than 0.070 kg
- 10 A box slides on frictionless ice and collides with another box sliding in the same direction. If the two boxes stick together after the collision, what assumption can be made about the type of collision that occurred?
- A It was a completely inelastic collision.
 - B It was an inelastic collision.
 - C It was an elastic collision.
 - D It was a completely elastic collision.
- 11 Which could cause a decrease in the momentum of a moving object?
- A a decrease in volume
 - B an increase in volume
 - C a decrease in speed
 - D an increase in speed

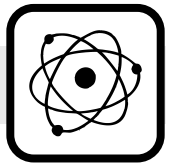

- 12 A 0.25-kg block is traveling along a horizontal, frictionless surface at a speed of 2.8 m/s. The block hits a wall and returns in the opposite direction at a speed of 1.7 m/s. What is the approximate impulse of the block on the wall?
- A 0.28 kg m/s
B 1.1 kg m/s
C 4.4 kg m/s
D 18 kg m/s
- 13 A student riding a bicycle doubles his speed. By what factor does the kinetic energy of the student and bicycle change?
- A $\frac{1}{4}$
B $\frac{1}{2}$
C 2
D 4
- 14 If a person reduces the acceleration of an object by a factor of two, what happens to the amount of work being done?
- A The magnitude of the work performed quadruples.
B The magnitude of the work performed doubles.
C The magnitude of the work performed is reduced by half.
D The magnitude of the work performed is reduced by one-fourth.

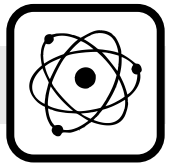

- 15 Spring X has a spring constant of 120 N/m and is compressed 0.23 m relative to its natural length. Spring Y has a spring constant of 150 N/m. How far does spring Y need to be compressed relative to its natural length for it to have the same amount of stored elastic potential energy as Spring X?
- A 0.21 m
B 0.29 m
C 0.43 m
D 0.61 m
- 16 A 75-kg box dropped from rest at the top of a 33-m high tower falls freely to the ground. How much kinetic and potential energy does the box have when it reaches 15 m above the ground? (Ignore friction.)
- A The box has 3.6×10^3 J of kinetic energy and 0.0 J of potential energy.
B The box has 1.1×10^4 J of kinetic energy and 1.3×10^4 J of potential energy.
C The box has 1.3×10^4 J of kinetic energy and 1.1×10^4 J of potential energy.
D The box has 2.4×10^4 J of kinetic energy and 0.0 J of potential energy.

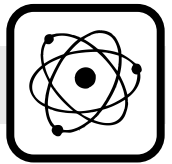

17 Machine X produces the **least** amount of power in a factory. Since power is determined by the amount of work done and the time it takes, which Work vs. Time graph explains the power produced by Machine X?

A **Work vs. Time**

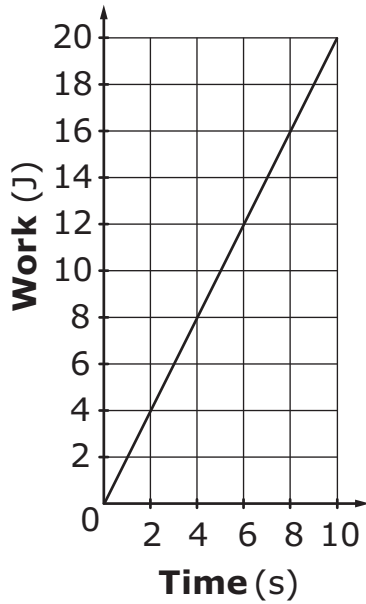

B **Work vs. Time**

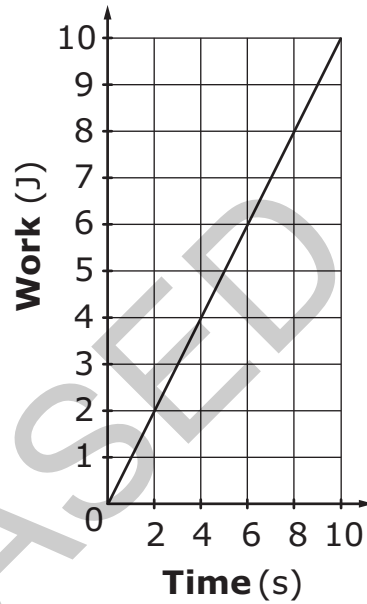

C **Work vs. Time**

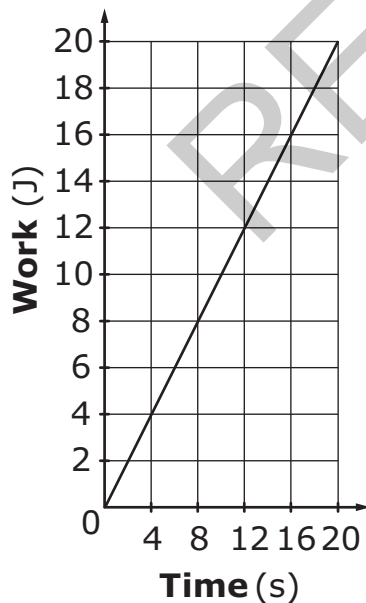

D **Work vs. Time**

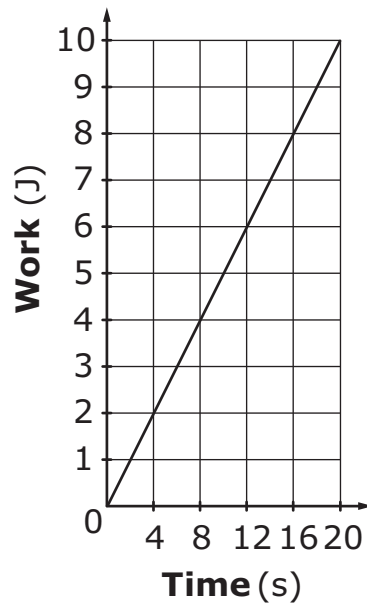

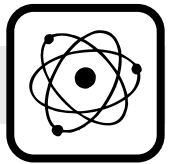

- 18 A person uses 25.0 J of kinetic energy to push an object for 11.0 s. How are work and power affected if the person uses the same amount of kinetic energy to push the object in less time?
- A The power will increase, and the amount of work will increase.
 - B The power will increase, and the amount of work will remain the same.
 - C The power will decrease, and the amount of work will remain the same.
 - D The power will decrease, and the amount of work will decrease.
- 19 An object produces a sound of constant frequency. If the object moves toward a student who is standing still, what happens to the pitch and the wavelength of the sound the student hears while the object is getting closer?
- A pitch increases, and wavelength decreases
 - B pitch increases, and wavelength increases
 - C pitch decreases, and wavelength increases
 - D pitch decreases, and wavelength decreases

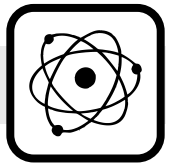

20 The diagram below represents a wave.

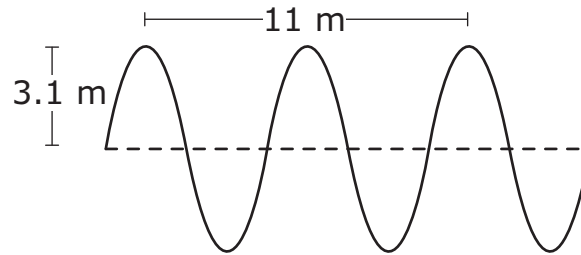

If its frequency is 25 Hz, what is the approximate speed of the wave?

- A 78 m/s
 - B 138 m/s
 - C 160 m/s
 - D 280 m/s
- 21 A ray of light traveling in water enters a different medium. If the incident angle of the ray is 47° , and the angle of refraction bends toward the normal, what does this reveal about the index of refraction of the medium?
- A The index of refraction of the medium is less than the index of refraction of water.
 - B The index of refraction of the medium is the same as the index of refraction of water.
 - C The index of refraction of the medium is greater than the index of refraction of water.
 - D The index of refraction of the medium is not comparable to the index of refraction of water.

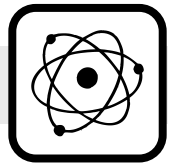

- 22 Which **best** describes the different mediums in which the speed of light and sound is greatest?
- A Light travels fastest through air, while sound travels fastest through a diamond.
 - B Light travels fastest through a diamond, while sound travels fastest through air.
 - C Light travels fastest through water, while sound travels fastest through glass.
 - D Light travels fastest through glass, while sound travels fastest through water.
- 23 A circuit has a voltage source and three identical resistors in parallel. How will removing one of the resistors affect the voltage of the circuit?
- A The voltage will stay the same because the voltage remains constant through parallel resistors.
 - B The voltage will increase by a factor of 2 because the voltage constantly increases through parallel resistors.
 - C The voltage will decrease by a factor of 2 because voltage is directly proportional to the number of parallel resistors a circuit contains.
 - D The voltage will increase by a factor of 3 because voltage is indirectly proportional to the number of parallel resistors a circuit contains.

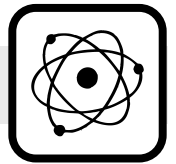

- 24 A circuit contains a voltage source and four resistors connected in series. If the voltage is decreased by one-half, what will happen to the current flowing through the circuit?
- A The current will decrease by one-fourth because current has an inverse relationship to the number of resistors that are in series.
 - B The current will decrease by one-half because current has a direct relationship to the voltage of the circuit.
 - C The current will double because current has an inverse relationship to the voltage of the circuit.
 - D The current will quadruple because current has a direct relationship to the number of resistors that are in series.
- 25 A scientist used a material which allowed electrons to move easily from atom to atom. What can be assumed about the material the scientist used?
- A The material was a conductor.
 - B The material was an insulator.
 - C The material was a thermal insulator.
 - D The material was a semiconductor.

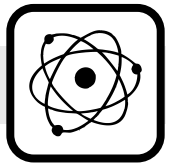

- 26 Two spheres, Sphere I and Sphere II, are composed of different substances. These diagrams show the distribution of the electrons in the two spheres before and after they are placed next to a positively charged rod.

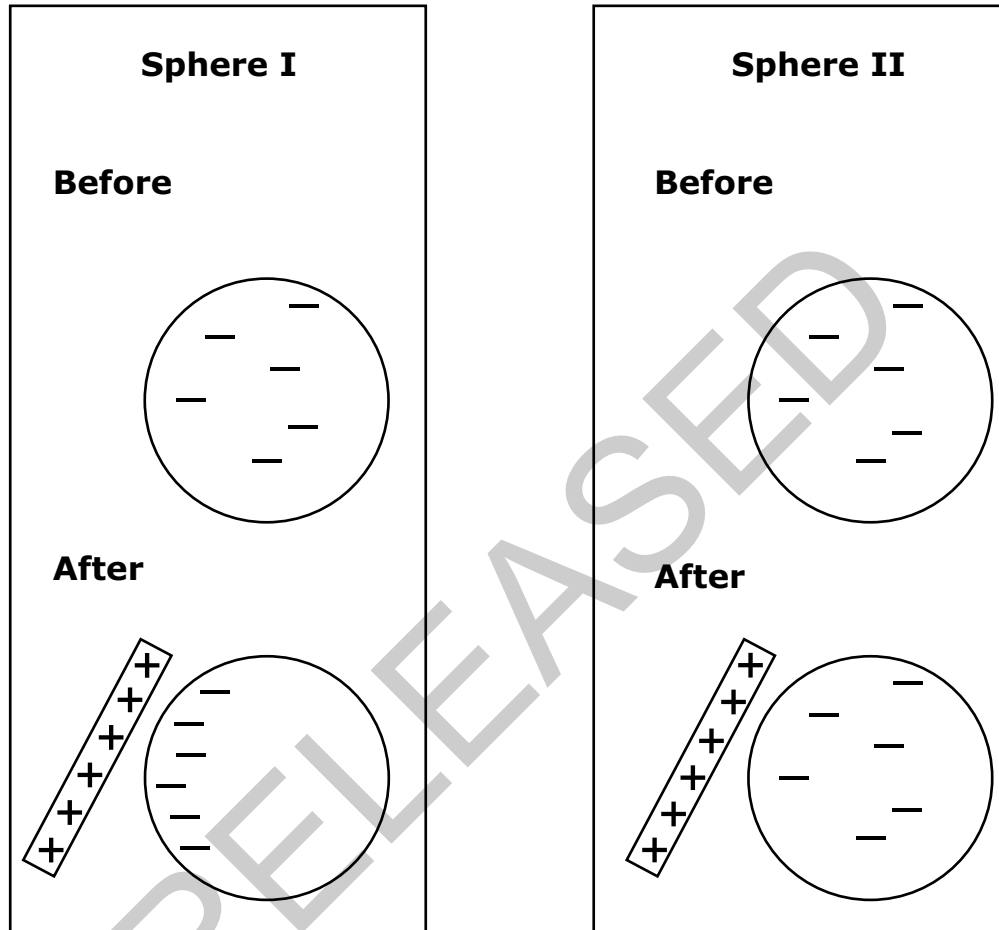

Which sphere is **most likely** composed of glass?

- A Sphere I, because the electrons are tightly bound
- B Sphere I, because the electrons are free to move
- C Sphere II, because the electrons are free to move
- D Sphere II, because the electrons are tightly bound

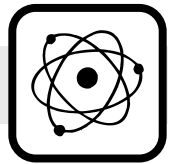

- 27 What is the main advantage of using alternating current (AC) over direct current (DC) when transmitting electricity?
- A AC has fewer power surge problems than DC.
 - B AC power lines need less insulation than DC power lines.
 - C AC makes it easier to step voltage up or down with transformers, as compared to DC.
 - D AC is not affected by the use of transformers, but the use of DC requires transformers.

- 28 The diagram below is of a circuit with a resistor.

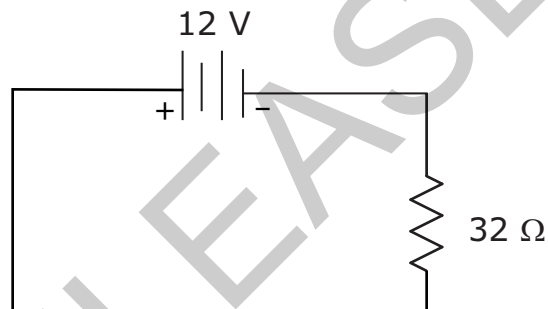

How much power does the resistor use?

- A 0.38 W
- B 4.5 W
- C 85 W
- D 380 W

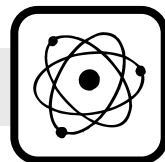

29 This diagram displays a circuit with two resistors.

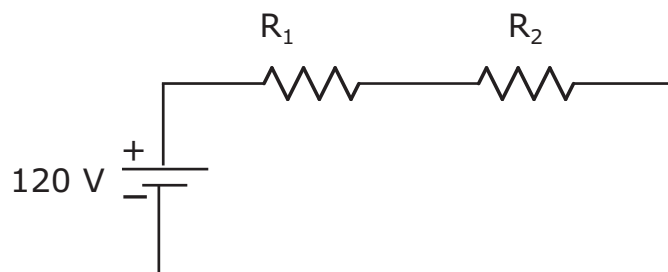

If the circuit produces 40 W, how much energy does it use in 20 s?

- A 2,400 J
- B 800 J
- C 6 J
- D 2 J

RELEASED



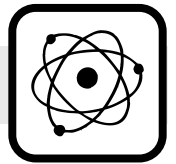

- 30 A charged pith ball is placed between two fixed charges. The pith ball swings in the direction shown.

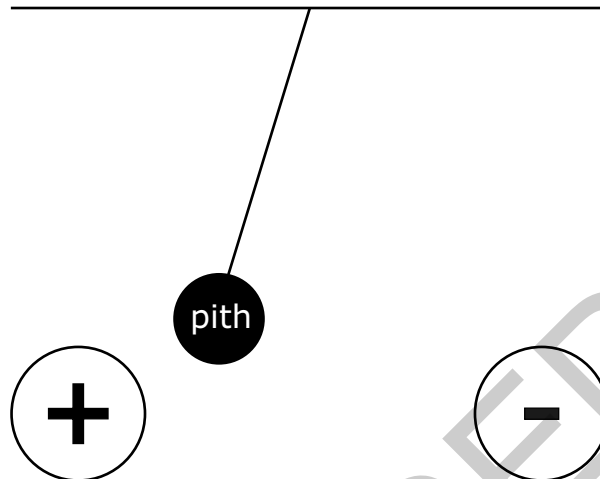

What is the charge on the pith ball?

- A positive, because unlike charges attract
- B positive, because unlike charges repel
- C negative, because unlike charges attract
- D negative, because unlike charges repel
- 31 The magnitude of an electric field created by a charge of 2.5×10^{-9} C is measured at a distance of 0.04 m. How will the magnitude change if the distance is increased?
- A The magnitude will decrease, because the electric field's strength decreases with increased distance.
- B The magnitude will decrease, because the electric field is directed inward toward the charge.
- C The magnitude will increase, because the electric field is directed outward from the charge.
- D The magnitude will increase, because the electric field's strength increases with increased distance.

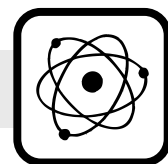

- 32 Two metal spheres (I and II) with charges of 1×10^{-6} C and 2×10^{-6} C, respectively, are separated by a distance. Sphere I experiences an electrostatic repulsion of 2.4 N from sphere II. What is the electrostatic repulsion force experienced by sphere II?
- A Sphere II experiences half the amount of repulsion force because it is twice as large as sphere I.
 - B Sphere II experiences the same amount of repulsion force because an equal and opposite charge is needed to balance the force experienced by sphere I.
 - C Sphere II experiences double the amount of repulsion force because it is twice as large as sphere I.
 - D Sphere II experiences four times the amount of repulsion force because an equal and opposite charge is needed to balance the force experienced by sphere I.
- 33 A student walks across a carpeted floor and acquires a static electric charge. Why is this an example of friction?
- A Heat is transferred from the floor to the student's feet.
 - B Heat is transferred from the floor to the air under the student's feet.
 - C Resistance is produced between the student's feet and the carpeted floor.
 - D Current is produced by the student's feet and the carpeted floor.

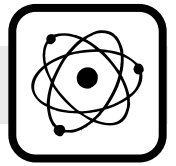

- 34 The electric potential at a point is 20 V. How much work is needed to bring a charge of 0.5 C from infinity to that point?
- A The work required to move the charge is equal to the electric potential at the point times the amount of charge being moved; therefore, 10 J of work is needed for this charge.
- B The work required to move the charge is equal to the electric potential at the point it is being moved to because the forces are equal and opposite; therefore, 20 J of work is needed for this charge.
- C The work required to move the charge is equal to the electric potential at the point over the amount of charge being moved; therefore, 40 J of work is needed for this charge.
- D The work required to move the charge is equal to the electric potential at the point over the square of the amount of charge being moved; therefore, 100 J of work is needed for this charge.

RELEASED

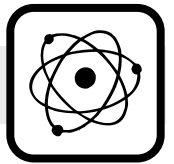

- 35 This figure shows the electric field around two positive charges placed near each other.

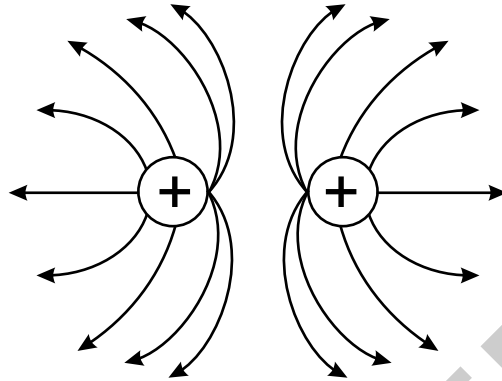

According to the electric field lines, how will the charges move?

- A They will move toward each other and spin because they are unbalanced charges.
- B They will move apart and in the same direction because one charge is larger than the other.
- C They will move toward each other and collide because like charges attract each other.
- D They will move apart and in opposite directions because like charges repel each other.

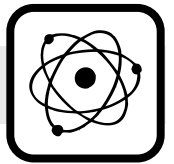

- 36 A bar magnet has been cut into four pieces of equal length and width. What is the pole strength of each piece compared to the pole strength of the original bar magnet?
- A double, because the magnetic domain only depends on the width of the magnet
 - B equal, because the magnetic domain is independent of the width and length of the magnet
 - C one-half, because the magnetic domain only depends on the length of the magnet
 - D one-fourth, because the magnetic domain depends on the length and width of the magnet
- 37 Which material will create the strongest magnetic field when a current-carrying wire is wrapped around the material?
- A a wool cloth, because wool is a thermal material
 - B a rubber tube, because rubber is an insulating material
 - C a glass pipe, because glass is a semi-conducting material
 - D an iron core, because iron is a conductive material
- 38 Which would result in an increase in the magnetic field strength produced by an electromagnet?
- A increasing the space between the turns in the coil
 - B increasing the number of turns in the coil
 - C decreasing the current in the coil
 - D decreasing the voltage in the coil

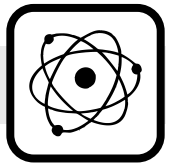

- 39 The primary coil of a transformer has 400 turns; the secondary coil has 1,000 turns. An alternating current is sent through the primary coil. The voltage in the primary coil has an amplitude of 17 V. Which statement **best** describes the voltage amplitude in the secondary coil?
- A between 0 V and 17 V, because transformer coils are insulators
 - B between 17 V and 50 V, because transformer coils are conductors
 - C between 0 V and 17 V, because the coils form a step-down transformer
 - D between 17 V and 50 V, because the coils form a step-up transformer
- 40 A transformer triples its input voltage. If the current in the primary coil is 6 A, how does the current change as it moves through the secondary coil?
- A It decreases to 2 A because this is a step-up transformer.
 - B It remains at 6 A because transformers are used to keep current constant.
 - C It increases to 9 A because transformers are used to keep voltage constant.
 - D It increases to 18 A because this is a step-down transformer.

This is the end of the multiple-choice portion of the test.

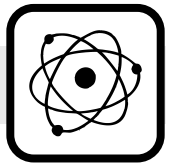

The questions you read next will require you to answer in writing.

1. Write your answers on separate paper.
2. Be sure to write your name on each page.

- 1 This diagram represents a DC circuit. Analyze the circuit, and answer the questions below.

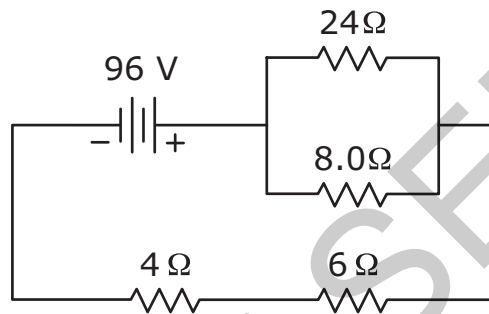

- What is the total resistance in this circuit?
 - How much current is flowing through this circuit?
 - How could a student rearrange the resistors in this circuit to allow more current to flow through it?
- 2 An object rolls off a 1.9-m-tall shelf with a constant horizontal velocity of 0.49 m/s. (Ignore all friction.)
- How much time will it take for the object to hit the ground?
 - What is the horizontal velocity of the object when it hits the ground?

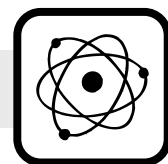

- 3 A 1,700-kg car moving at 16 m/s has 100 m of road to make a complete stop before hitting a wall.
- If it takes 7.0 s for the car to come to rest, what is the force required to stop the car? (Assume acceleration is constant.)
 - Using Newton's laws of motion, explain if the force is enough to stop the car before it hits the wall.

RELEASED

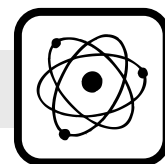

This is the end of the Physics test.

- 1. Look back over your answers.**
- 2. Put all of your papers inside your test book and close the test book.**
- 3. Place your calculator on top of the test book.**
- 4. Stay quietly in your seat until your teacher tells you that testing is finished.**

RELEASED

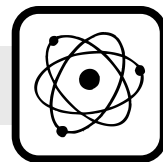

**Physics
RELEASED Form
Spring 2013
Answer Key**

Item number	Type	Key	Unifying Concept
1	MC	C	Forces and Motion
2	MC	C	Forces and Motion
3	MC	B	Forces and Motion
4	MC	C	Forces and Motion
5	MC	D	Forces and Motion
6	MC	B	Forces and Motion
7	MC	D	Forces and Motion
8	MC	D	Forces and Motion
9	MC	C	Forces and Motion
10	MC	A	Forces and Motion
11	MC	C	Forces and Motion
12	MC	B	Forces and Motion
13	MC	D	Energy: Conservation and Transfer
14	MC	C	Energy: Conservation and Transfer
15	MC	A	Energy: Conservation and Transfer
16	MC	C	Energy: Conservation and Transfer
17	MC	D	Energy: Conservation and Transfer
18	MC	B	Energy: Conservation and Transfer
19	MC	A	Energy: Conservation and Transfer
20	MC	B	Energy: Conservation and Transfer
21	MC	C	Energy: Conservation and Transfer
22	MC	A	Energy: Conservation and Transfer
23	MC	A	Energy: Conservation and Transfer

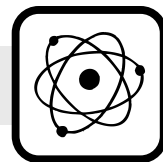

Item number	Type	Key	Unifying Concept
24	MC	B	Energy: Conservation and Transfer
25	MC	A	Energy: Conservation and Transfer
26	MC	D	Energy: Conservation and Transfer
27	MC	C	Energy: Conservation and Transfer
28	MC	B	Energy: Conservation and Transfer
29	MC	B	Energy: Conservation and Transfer
30	MC	C	Interaction of Energy and Matter
31	MC	A	Interaction of Energy and Matter
32	MC	B	Interaction of Energy and Matter
33	MC	C	Interaction of Energy and Matter
34	MC	A	Interaction of Energy and Matter
35	MC	D	Interaction of Energy and Matter
36	MC	B	Interaction of Energy and Matter
37	MC	D	Interaction of Energy and Matter
38	MC	B	Interaction of Energy and Matter
39	MC	D	Interaction of Energy and Matter
40	MC	A	Interaction of Energy and Matter
41	CR	Rubric	Energy: Conservation and Transfer
42	CR	Rubric	Forces and Motion
43	CR	Rubric	Forces and Motion

Item Types:

MC = multiple choice

CR = constructed response